

The CENTURY 6500 Tilt Double Hung window is engineered to achieve the highest AAMA industry standards: Heavy Commercial (HC) and Architectural Window (AW) grades. This thermally-broken window, featuring a 4 1/8" frame and concealed tilt latches, is required to pass rigorous life cycle testing to simulate many years of abuse. The CENTURY 6500 is designed for the most demanding building applications. All of Champion's installation accessories including panning, snap trim, and receptors are available on this product. The CENTURY 6500 is perfect for mid and high-rise buildings where high levels of performance are desired. While utilizing the same master frame as the 6500, the CENTURY 6200 Tilt Dual Glazed window is used in applications that require different glazing materials on the sash interior and exterior. The dual glazed version is a perfect choice for schools or buildings concerned about glass breakage. The CENTURY 6800 is a 4 1/8" Sideload window that is ideal for schools and large installations where safety and security are important.

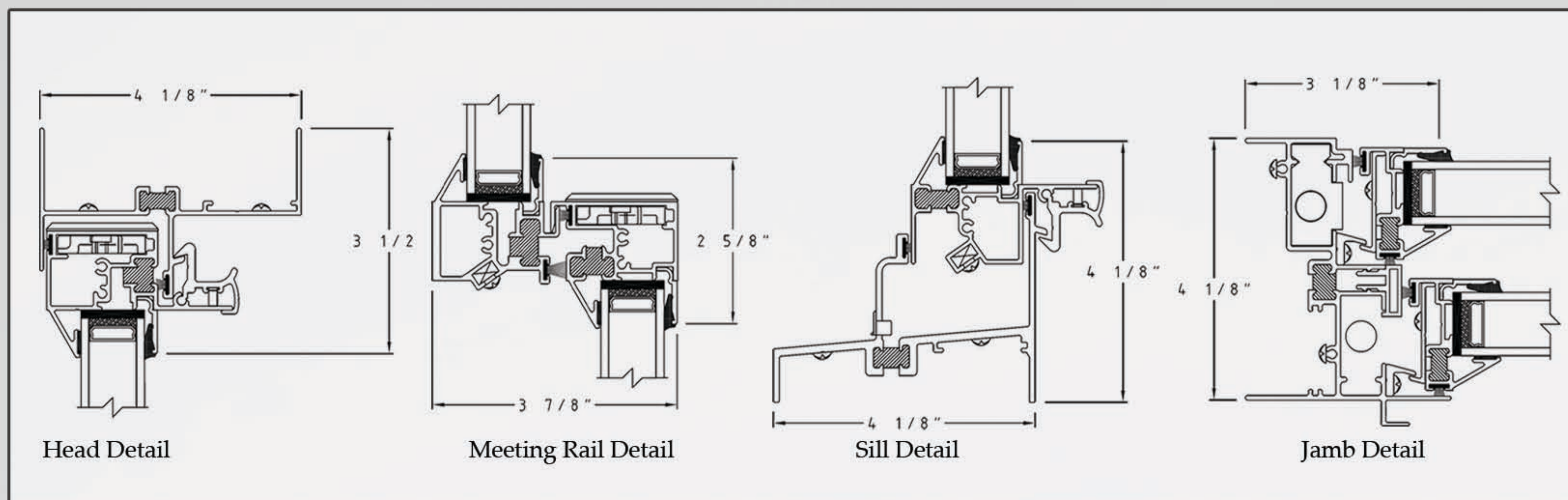

~Quality Products and Service Since 1952~

Century Features

HC and AW Rated Products	Metal Sash Stops w/ Rubber Bumpers	Fully Thermally-Broken Components
4 1/8" Frame Depth	Concealed Tilt Latches	Auto Engage/Release Sashes
1" Insulating Glass (6500/6800)	Tamper-proof Tilt Latches	Hospital Pocket Sill
Dual Sealed D/S Glass (6500/6800)	Anti-Bow Clips	Solid Stainless Steel Pivot Bars
1/4"-1/4" Glass (6200)	Metal End Caps	Structural Glazing
0.070 Extrusions	Continuous Anti-Drift/Top Lock Rail	Baked Enamel Finish
0.125 Sill	Full Length Knife-Edge Interlock	Sill Mounted Jamb
Beveled Sashes	Continuous Lift/Lock Rail	Maximum Test Height: 60"W x 99"H

Century Options

Series 97 Balances (6200/6500/6800)	Louvers
Ultralift Balances (6200/6500)	Trickle Vents
Super Lift Balances (6200/6500)	L-Angles
EZ Lift Balances (6200/6500)	Receptor/Subsill
Dual Balances	Sheet Rock Receptor
Extended Fin Options	Twist Anchors
1", 2" & 5 1/2" Expander	Snap Trim
3" & 5" Dual Expander	Square Panning
Sill Covers	Landmark Panning
Stool Covers	Internal Grids
Tie-in Mullion (6200/6500)	Landmark Grids
3-Piece Million	Child Guards
True Divide Muntins (6500/6200)	Screen Options
2-Piece Mullion Covers	Solid Panels
Caulk Return	Multiple Configurations
Caulk Stop w/ Return	



Metal Sash Stops



Continuous Lock Rail



Concealed Tilt Latches



Beveled Sashes



Century Performance

Champion's Century Double Hung windows are AAMA certified, with test results meeting all the requirements for their respective ratings in accordance with the 101/I.S.2/A440-05 or 101/I.S.2/A440-08 testing standards. As part of its commitment to quality, Champion maintains a testing facility that it uses to continuously test its products, ensuring that they continuously meet requirements.

Title of Test	6200/6500 H-AW-PG55	6800 H-AW-PG50	6510 FW-AW85
Operating Force	42 lbf max	36 lbf max	-
Air Infiltration	0.25 cfm ² @ 50mph	0.19 cfm ² @ 50mph	<0.01 cfm ² @ 50mph
Water Resistance Test Pressure	12.12 psf	15.05 psf	12.12 psf
Uniform Load Deflection Test Pressure	55.17 psf	50.16 psf	90.28 psf
Uniform Load Structural Test Pressure	82.76 psf	75.24	127.9 psf
Forced Entry Resistance	Grade 10	Grade 10	Grade 40